



WESSEX 'HOMELIFT'

VM RANGE



Technical Sales Specification



©Copyright 2009

Wessex Lift Co Ltd

All Rights Reserved

Except as expressly provided below, no part of this manual may be reproduced, copied, transmitted, disseminated, downloaded or stored in any storage medium, for any purpose without the express prior written consent of Wessex. Wessex hereby grants permission to download a single copy of this manual and of any revision to this manual onto a hard drive or other electronic storage medium to be reviewed and to print one copy of this manual or of any revision hereto, provided that such electronic or printed copy of this manual or revision must contain the complete text of this copyright notice and provided further that any unauthorised commercial distribution of this manual or any revision hereto is strictly prohibited.

Information in this document is subject to change without notice. Wessex reserves the right to change or improve its products and to make changes in the content without obligation to notify any person or organisation of such changes or improvements

Wessex Lift Co Ltd
Budds Lane,
Romsey, SO51 OHA, UK

Tel. (+44) 01794 830303
Fax. (+44) 01794 512621

Web site address: www.wessexlifts.co.uk

RECORD OF REVISIONS

Revision	Revision Date	Description	ECO
A	08/09/2009	Production release	1376
B	13/07/2011	Lift capacity changed to 250kg	1419



Contents

1. Introduction.....	4
2. Product Range and Specifications.....	5
3. Door Construction and operation.....	9
4. Controls.....	9
5. Illumination.....	10
6. Grab Handles.....	10
7. Track System.....	10
8. Seat.....	10
9. Finish.....	11
10. Alarm Facilities.....	11
11. Electrical Requirements.....	11
12. Battery Backed Features.....	11
13. Applicable Standards.....	11
14. Safety Features.....	12
15. Options.....	12
16. Method of installation.....	13



1. Introduction.

The drawing below shows the typical Homelift installation. The Homelift is designed for single person use in a domestic dwelling. When travelling in the lift car, the person must be either seated or in a wheelchair. The lift must not be fitted into bathroom environments or damp/humid conditions.

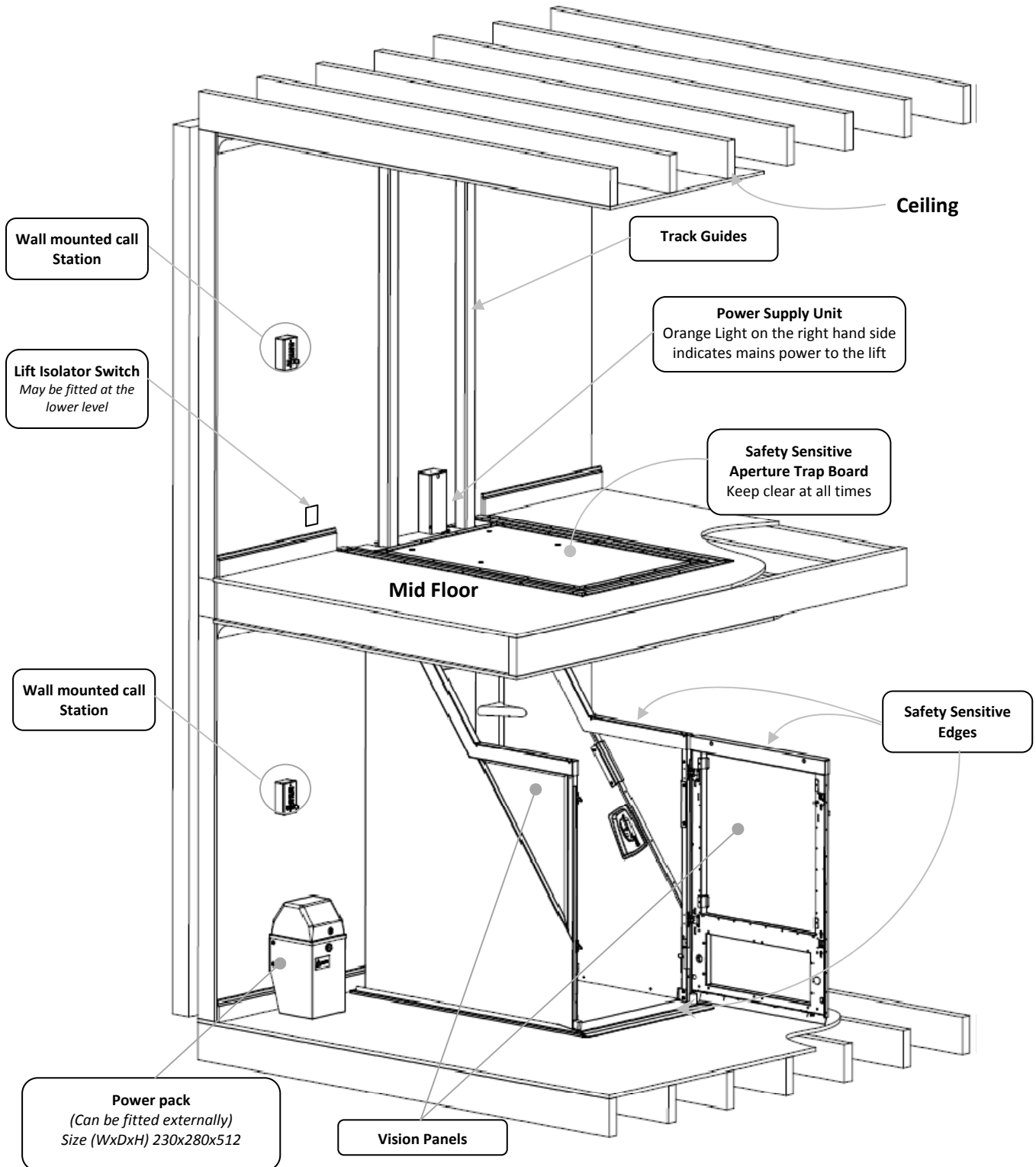



2. Product Range and Specifications.

The table below details the standard specification for the Wessex “Homelift” range.

STANDARD SPECIFICATION	VM30	VM31	VM36	VM50	VM51	VM56
Standard Seated Lifts	✓	-	-	✓	-	-
Standard (Type A) Wheelchair Lifts	-	✓	-	-	✓	-
Large (Type B) Wheelchair Lifts	-	-	✓	-	-	✓
3000mm Maximum Travel	✓	✓	✓	-	-	-
3500mm Maximum Travel	-	-	-	✓	✓	✓
Minimum shaft width	846	996	1046	846	996	1046
Minimum shaft length	1120	1505	1555	1120	1505	1555
Minimum first-floor ceiling height	2040			2280		
Mid-floor dimensions	from 165mm to 385mm			from 165mm to 385mm		
Safe Working Load	250kg (39 stone)			250kg (39 stone)		
Trap board Safe Working Load	250kg (39 stone)			250kg (39 stone)		
Lift Speed	60mm/sec			60mm/sec		
Ramp Gradient	1:8			1:8		
Door Adjustment	Up to 95°			Up to 95°		

2.1 Reference Documentation.

The table below details the technical information available for the Wessex ‘Homelift’ range. The following documents must be referred to before commencing any work.

Drawing No	Description
VM10 7001	VM Lift Dimensions
VM00 6012	Mid Floor Details 400mm Joist Centres
VM00 6013	Mid Floor Details 600mm Joist Centres
VM30 9001	Structural Loadings
VM30 9006	VM Electrical Instructions
VM30 9007	VM Electrical Instructions New Build
VM30 9004	Building Instructions Aperture cut-out Details
VM30 9009	Building Instructions for Shafted Lifts
VM30 9008	Floor Run Out
VM30 9005	Aperture Trim Fixing
VM00 2010	Track Installation Drawings
VM30 9002	Pump Information



2.3 Lift Car Dimensions.

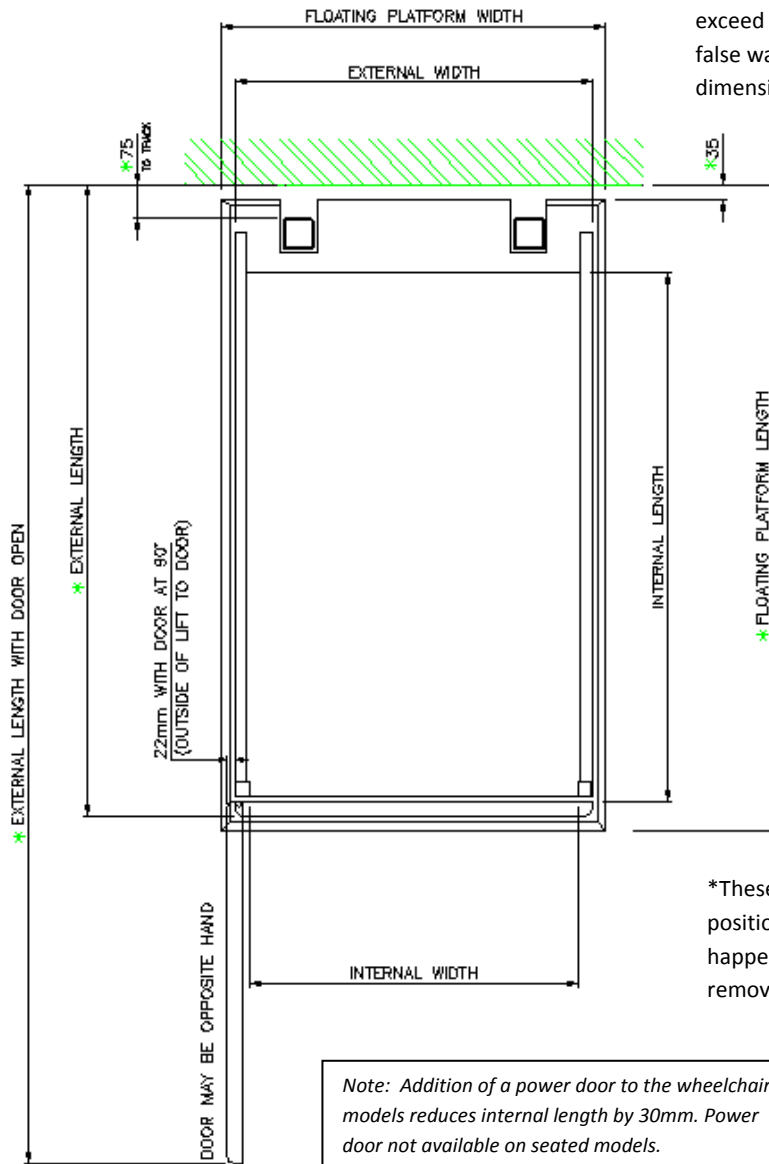

If the gap between the tracks and the rear wall exceed 150mm downstairs and 100mm upstairs, a false wall (track infill) will be required. Nominal dimension is 75mm

*These dimensions will increase if the lift is positioned away from the rear wall. This may happen if skirting boards etc... are not removed.

Model	Length				Width		
	Lift External	Lift Internal	Lift Door Open	Floating Platform	Lift External	Lift Internal	Floating Platform
VM30/VM50	1031	790	1655	1090	667	590	722
VM31/VM51	1416	1180	2190	1475	817	740	872
VM36/VM56	1466	1230	2290	1525	867	790	922



2.4 Minimum Ceiling Dimensions.

The diagram below details the following critical dimensions for each model type :-

- Minimum ground to floor ceiling height
- Minimum first floor ceiling height
- Maximum and minimum mid-floor thickness
- Maximum travel

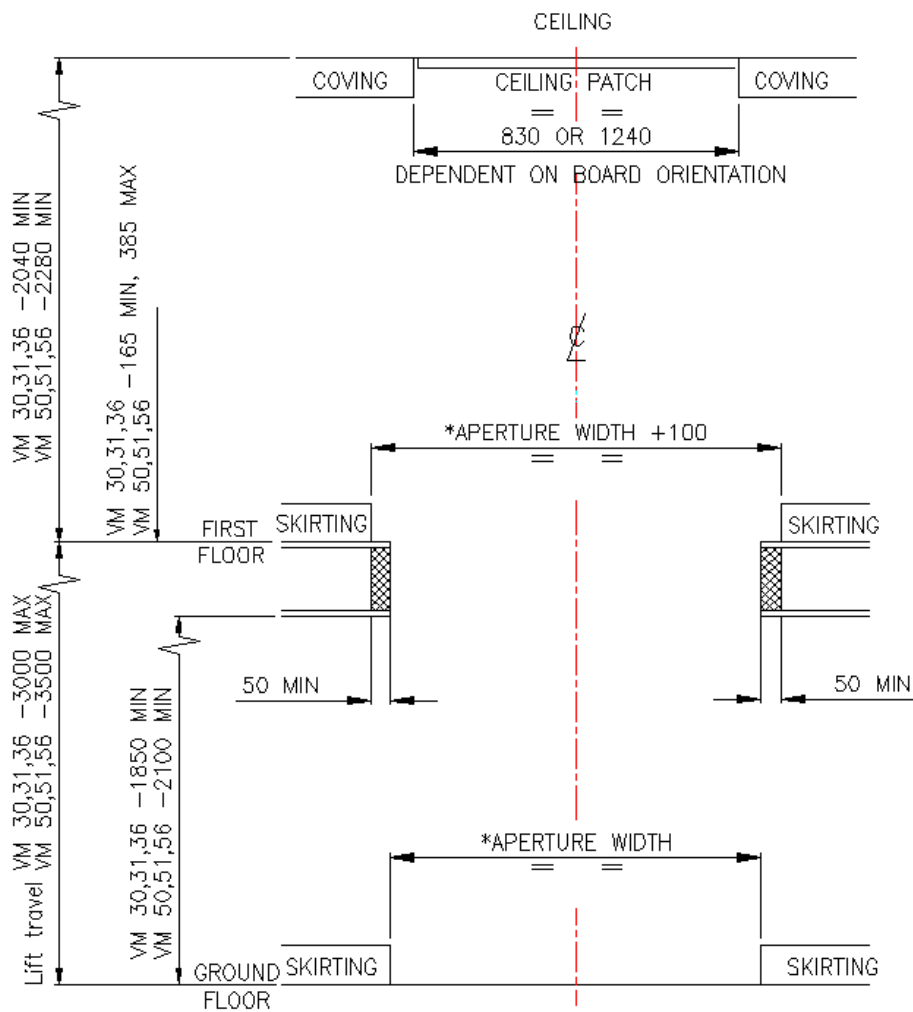

APERTURE CROSS SECTION FRONT VIEW

(*Note: Skirting boards can remain if the aperture is moved away from the rear wall)

	VM30/31/36	VM50/51/56
Minimum ground floor ceiling height	1850mm	2100mm
Minimum first floor ceiling height	2040mm	2280mm
Maximum travel	3000mm	3500mm
Mid floor Range	165mm to 385mm	165mm to 385mm



2.5 Aperture Dimensions.

Refer to VM30 9004 for comprehensive aperture details, and VM30 9009 for shafted aperture details.

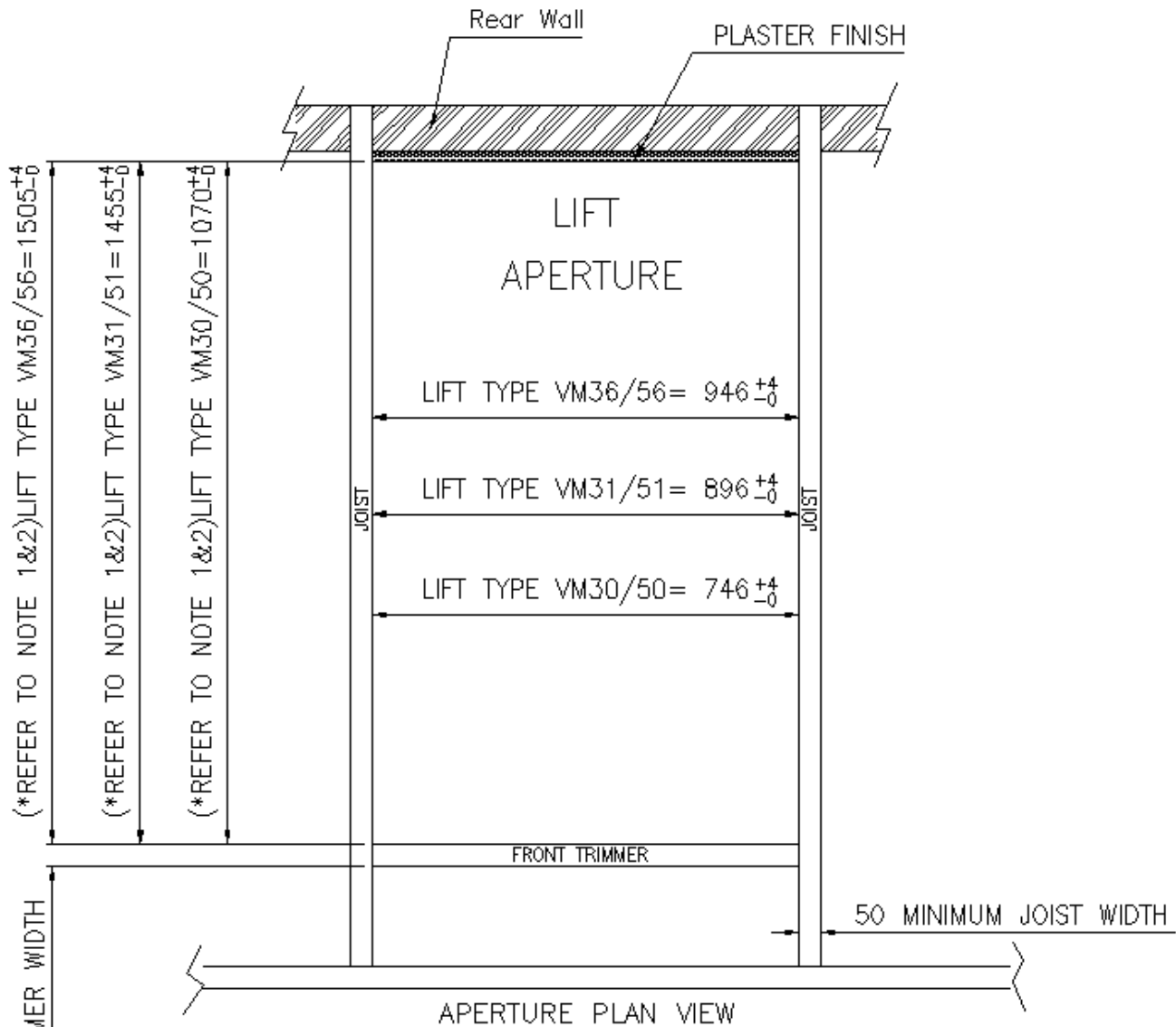

THE TIMBER JOISTS & TRIMMERS ARE ALWAYS REQUIRED AS THEY FORM THE STRUCTURE TO FIX OUR STEEL APERTURES TO, EVEN WHEN FITTED IN A SHAFT.

THERE ARE 3 SIZES OF LIFT APERTURE: VM30/VM50
VM31/VM51
VM36/VM56



3. Door Construction and operation.

The VM30 & VM50 models have a manually operated door. The lock is held open for approximately 5 seconds, when the door button or door safety edge is pressed. This allows single handed operation of the door to release and open. The door opens up to a maximum of 95°.

The VM31, 36, 51 & 56 models all have the option of a powered door with one touch operation. An auto-door close option is also available on these models. The door can be hinged on either side. The powered door can be manually overridden and has a safety breakout mechanism to protect the user from injury.

4. Controls.

The lift can be operated by using either, the In-car controls, upper level call station or lower level call station.

Auto-homing to first floor is optional. When the lift is at the ground floor, after a set period of time the lift will ascend to the upper level. When at the upper level it provides a fire-seal in accordance with BS 5900. The powered auto door close option is also recommended if auto-homing is required.

Radio control is optional.

Hold to run controls are optional. Mandatory when the TÜV option is required.

4.1 Car Controls.

The car controls are located in a recessed pod and can be fitted either side of the lift car. The controls illuminate to indicate what functions are available. They will extinguish after a set period of time to conserve energy. The push buttons and in-car lighting will illuminate when the light button or door release button is pressed.

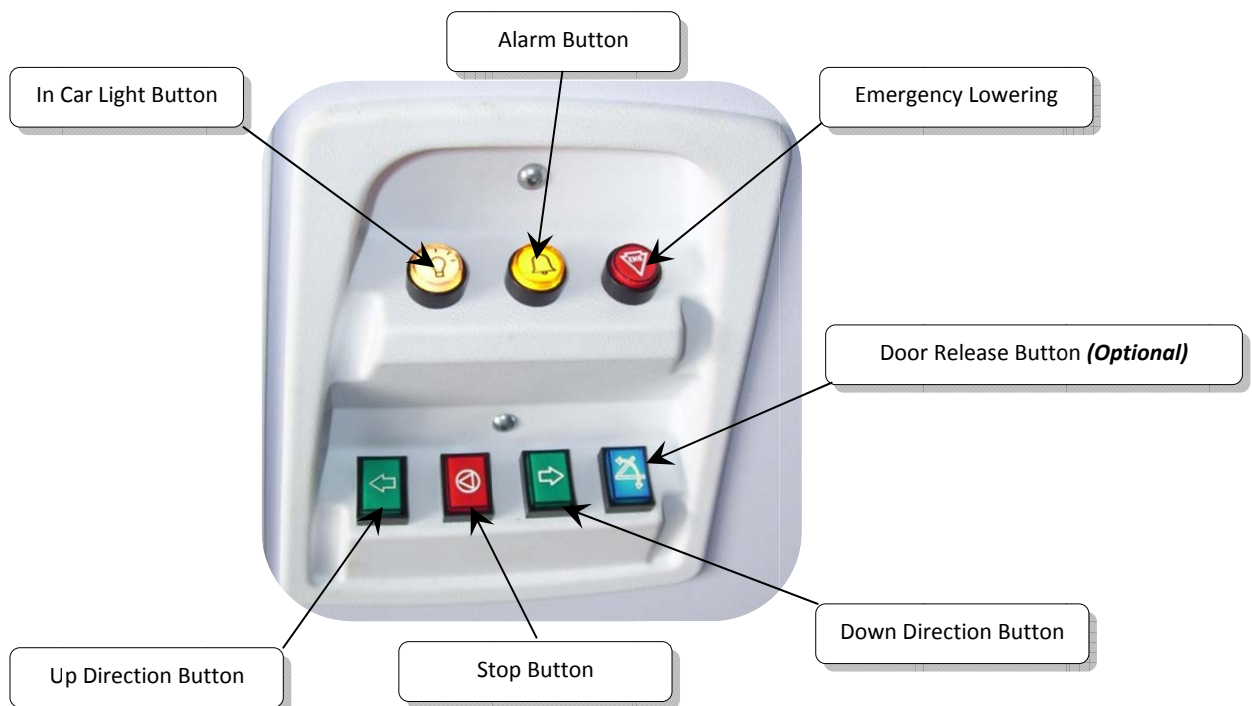



4.2 Call Station Controls.

Call stations are surface mounted but can be made flush finished by special request. The call station controls do not illuminate. The lower call station wire is run through the mid-floor and vertically down the wall. The upper call station is run through the mid-floor and vertically up the wall.

Key-switches are optional but recommended for dwellings that require the lift controls to be isolated. This prevents unauthorised use by children.



5. Illumination.

Low voltage LED's mounted at the back of the lift car. These have the same elapsed timer feature as the in-car push button illumination. The lights are triggered via any door control or the in-car light switch (or when a power failure).

6. Grab Handles.

Universal design for front or side mounting.

Front mounting only on VM30 & VM50 models.

Front or side mounting on VM31/36/51/56 models.

7. Track System.

Fixings at ground floor, mid floor via structural beam and ceiling fix at first floor level. An optional wall bracket is available at the first floor level, if ceiling fixing is not achievable.

8. Seat.

The standard seat can be set as a perch or bench type seat in a range of heights.

A lap strap is also available.

Four point safety harness available by special request.

<u>Type</u>	<u>Model</u>	<u>Height (mm) (floor to cushion)</u>
Perch/Tip Up	VM 30, 31, 36, 50, 51, 56	540/590/670/740



9. Finish.

For internal domestic use only.

Metalwork powder coated textured finish. Pearl Grey BS4800 22B-15

Internal plastic panels textured lavender colour.

10. Alarm Facilities.

In-car two tone alarm is fitted as standard, which is operated by a push button within the lift car.

A volt free contact is available as standard which allows the push button control to operate a remote mounted alarm. Provision is made to allow the fitting of a phone into the lift car.

11. Electrical Requirements.

Supply 220v -240v 50Hz single phase earthed supply.

Power consumption:

- 24 hours on standby = 0.396kWh
- One complete cycle = 0.0246kWh
- VM full load running current = 6.6amps

The supply must be dedicated solely to the lift and shall originate at the household consumer unit. Must be RCD protected. Refer to VM30 9006 for full details.

Pre-payment coin metres are not recommended.

12. Battery Backed Features.

The following functions within the lift will still function in the event of a power failure:

- In-car emergency lowering will become active
- Floating platform safety switches
- Trapboard safety switches
- Illumination of car and push buttons
- Manual door release
- Powered door (if fitted)
- Alarm

13. Applicable Standards.

Complies with the Machinery Directive 2006/42/EC

Built in accordance with BS 5900: 1999 Specification for Powered Domestic Lifts

TÜV Option has been Type tested by TÜV to the Machinery Directive 2006/42/EC



14. Safety Features.

- Sensitive edges around the top of the lift car periphery.
- Sensitive surface to car underside.
- Door electrically interlocked. Will only open when at the correct level.
- Power door breakout mechanism. Door will stop if obstructed.
- Manual door release key. The door can be manually opened in the event of a door release failure. This must only be used when the lift is either at the upper or lower level.
- Sensitive surface to trapboard sensing up and down obstructions.
- Separation and zone switches on trapboard.
- Fire seal when lift is upstairs.
- Pipe burst valve integral to base of hydraulic ram.
- Anti-creep and re-levelling facility at first floor.
- Low voltage 24V dc control system (PELV).
- Fire retardant materials throughout.
- Final limit switch.
- Overrun timer.
- Shoot bolt which maintains fireseal when lift is parked upstairs if there is a hydraulic failure.
- In-car battery backed emergency lowering. The lift can be lowered to the ground floor by pressing the in-car emergency lowering button in the event of a power failure.
- Manual emergency lowering at the power pack. The lift can be lowered in the event of a power failure from the power pack. *Note: This procedure will only work if the lift is at least 50mm below the upper level.*

15. Options.

- Door Closing Strap – A textured rope type pull cord is fitted to all manual doors as standard to allow the door to be closed easily from within the lift.
- Grab Handles – With front or side mounted positions available, these handles allow the user points on which to ease themselves into the lift car.
- In-car Lighting – Internal illumination of the lift car is provided which automatically switches off when the lift is not in use. The lighting is operational via battery back up in the event of a power failure. This is fitted as standard.
- In-car Seating – An in-car seat option is available. Maximum rated load of the seat is 140kg. The seat can fold up neatly away by simply lifting the front edge of the seat up until it is in the vertical position.
- Lap Strap – Where in-car seating is selected a lap strap with quick release buckle can be offered to suit.
- Radio Control – A radio controlled option is available to control some functions of the lift.
- Telephone – An in-car telephone option is available.
- Autohoming – An autohoming option is available. This will automatically send the lift to the upper level after a set period of time when the door is in the closed position. ('Homed' position).
- Auto-door Closing – An auto-door closing option is available. This will automatically close the lift door after a set period of time.
- In-car Key-switch – An in-car key-switch option is available. This will disable the up, down and stop button on the in-car control panel. This option must only be used if the user of the lift is not physically or mentally able to use the in-car controls. The lift must be supervised at all times when in use.



- Smoke Alarms – Mains powered (battery backed) smoke alarms are available. The smoke alarms are connected to the lift and will call the lift to the upper level if triggered in the event of a fire. Please note the lift door must be closed for this to work.
- Wall Mounted Controls with a Key-switch – Wall Mounted Controls with a Key-switch option is available. Key-switches are optional but recommended for dwellings that require the lift controls to be isolated. This prevents unauthorised use by children. The up and down buttons can be turned off, but the door button (*if fitted*) will remain active.

16. Method of installation.

There are 2 steps to installing any product from the VM range:

- The building work (forming aperture and fitting the aperture liner & trap-board) (Approx 2 days).
- Track system and lift installation. (Approx 2 days).

16.1 Building works.

A builder and Electrician will be appointed at placement of order. The builder will be responsible for forming the aperture, fitting the aperture lining components, removing skirting, dado and any picture rails where necessary. A qualified electrician will install the mains power to the lift at the same time. This will involve fitting a RCD protected dedicated supply from the main distribution board.

16.2 Installation.

The installation engineers will cut and fit the tracks and lift car and then commission the lift.

The benefits to this approach are:

- Standard track lengths allows batch production of both top and bottom track components.
- Despatch for regional and agents stock holding of tracks becomes feasible with this method of manufacture and design.
- The complete package can be project managed and controlled by Wessex Lift Co Ltd.

The basic installation sequence after the builders work has been completed is as follows: -

Basic Build Sequence

1. Fit Tracks
2. Fit Ram and ram housing along with power pack
3. Attach lift car on tracks in the following order; -
 - Carriage
 - Sides
 - Floor
 - Adjust and set tensioning devices
 - Floating Platform
 - Electrical Connections
 - Trap board and front pick up mechanisms
 - Panel out car
 - Fit seat if applicable
 - Fit handles if applicable
 - Fit phone if applicable